

# Enterprise Specifications

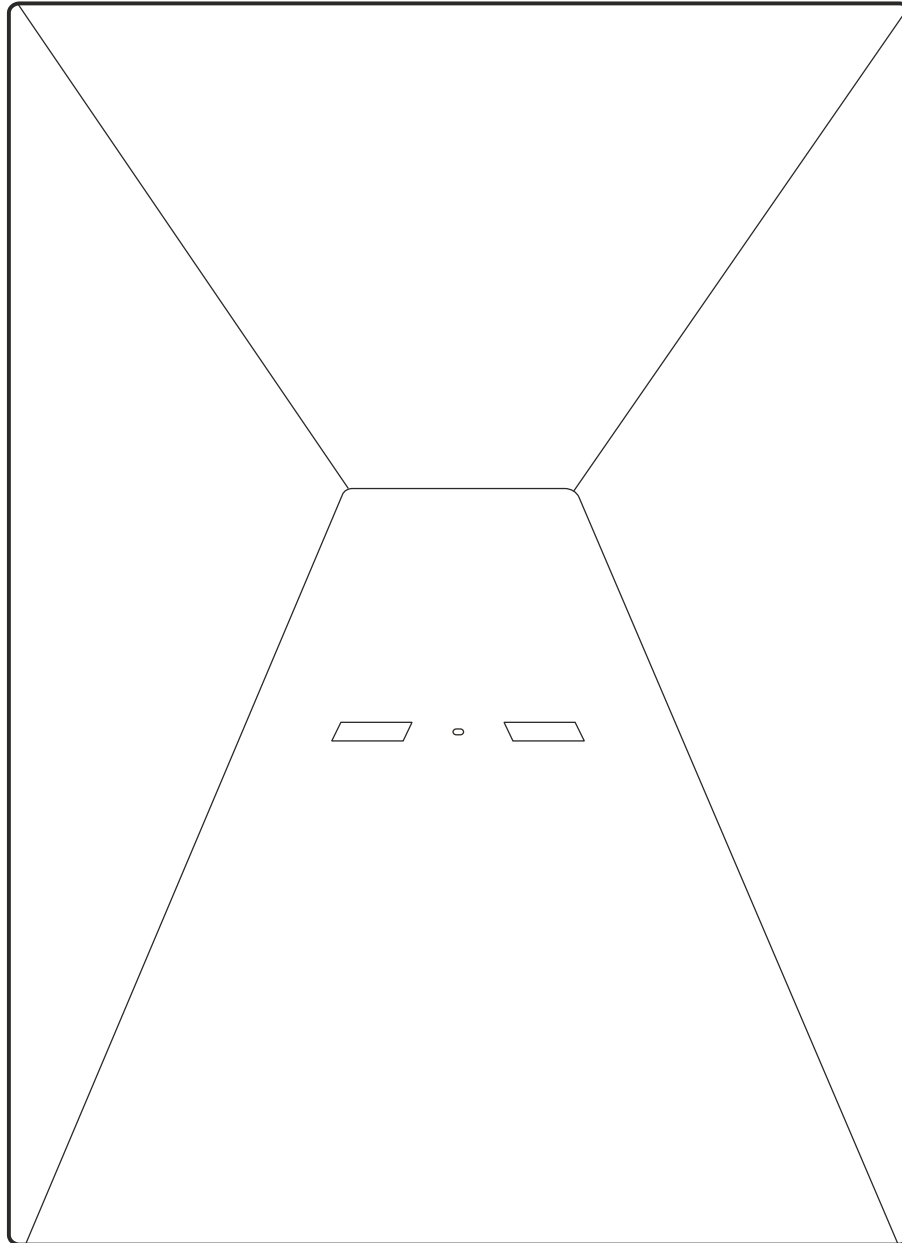

## What's in the Box:

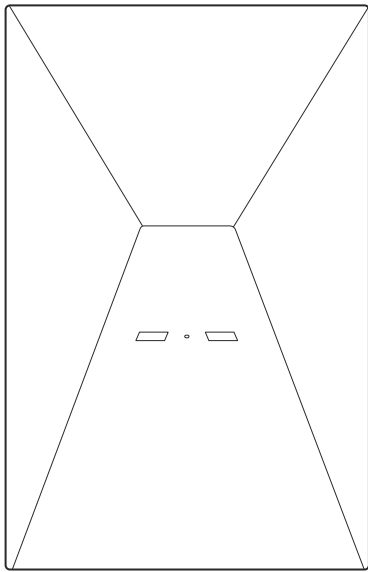

Standard

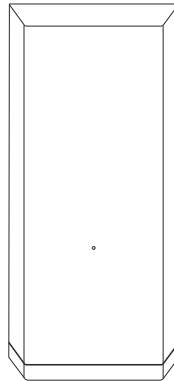

Power Supply

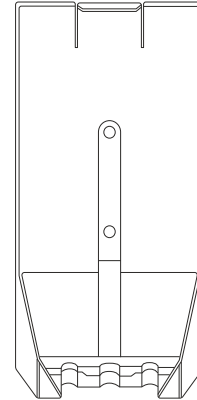

Power Supply Mount

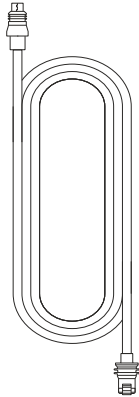

Enterprise Cable  
50 M  
(164.ft)

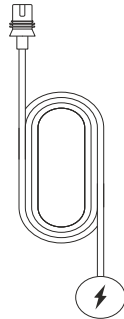

AC Power Cable  
1.8 M  
(6.ft)

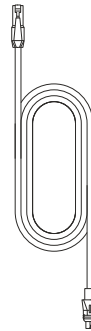

Ethernet Cable  
5 M  
(16.5.ft)



Screws  
4x

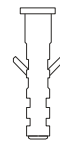

Wall Anchors  
4x

Package Weight 12.2 kg (27 lbs)

Package Dimensions : 478.1 x 685.9 x 160.1 mm (18.8 x 27 x 6.3 in)

# STARLINK

# Dish

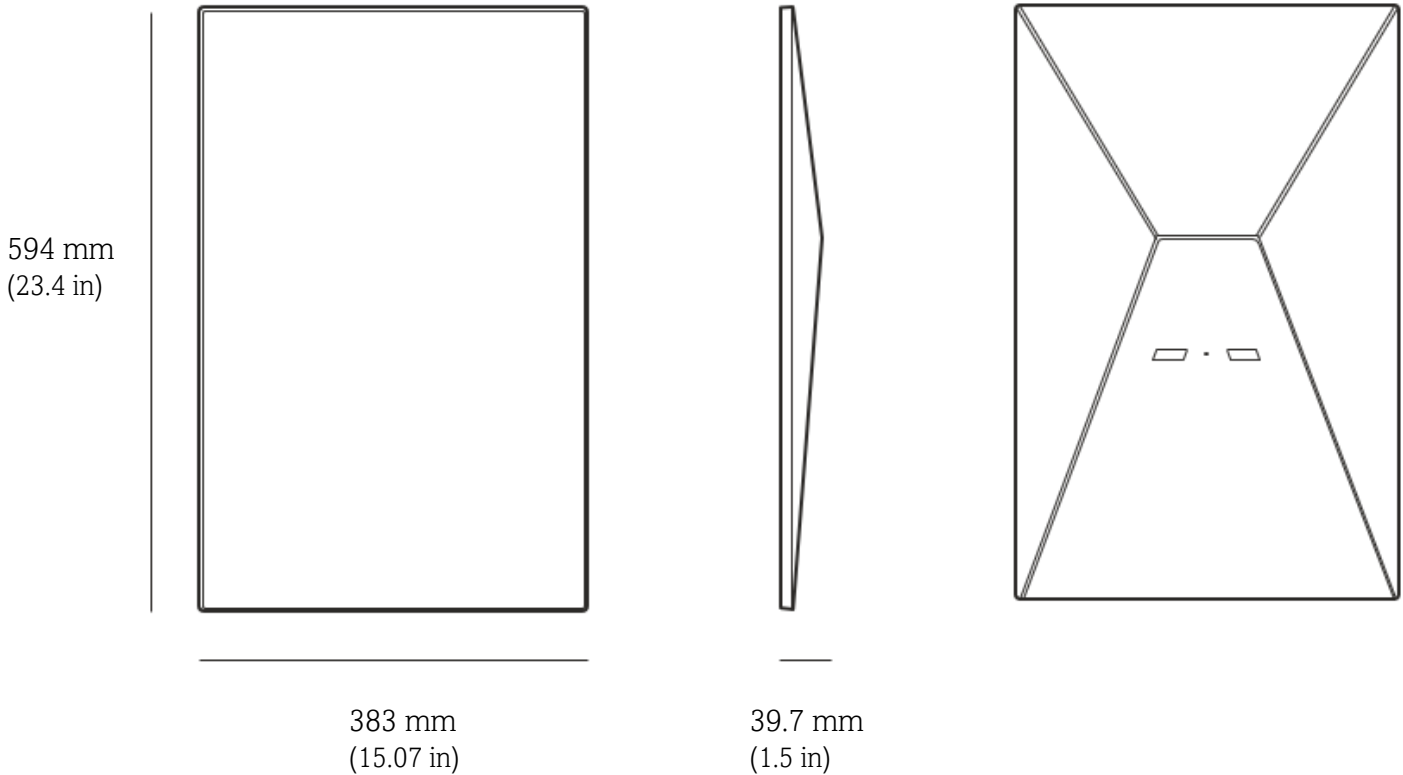

Antenna:	Electronic Phased Array
Field of View:	110°
Orientation:	Software Assisted Manual Orienting
Environmental Rating:	1P67 Type 4
Operating Temperature:	-30°C to 50°C (-22°F to 122°F)
Wind Speed:	Operational: 96 kph+ (60 mph+)
Snow Melt Capability:	Up to 40 mm / hour (1.5 in / hour)
Power Consumption:	Average: 75 - 100 W

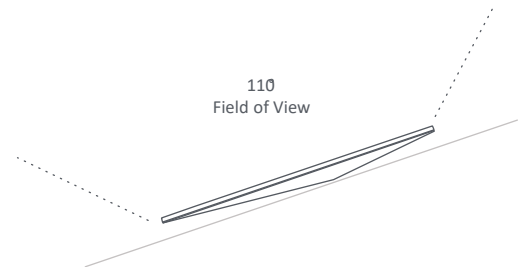

# Power Supply

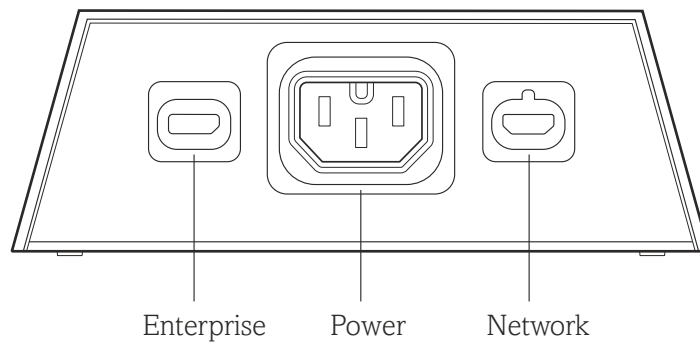
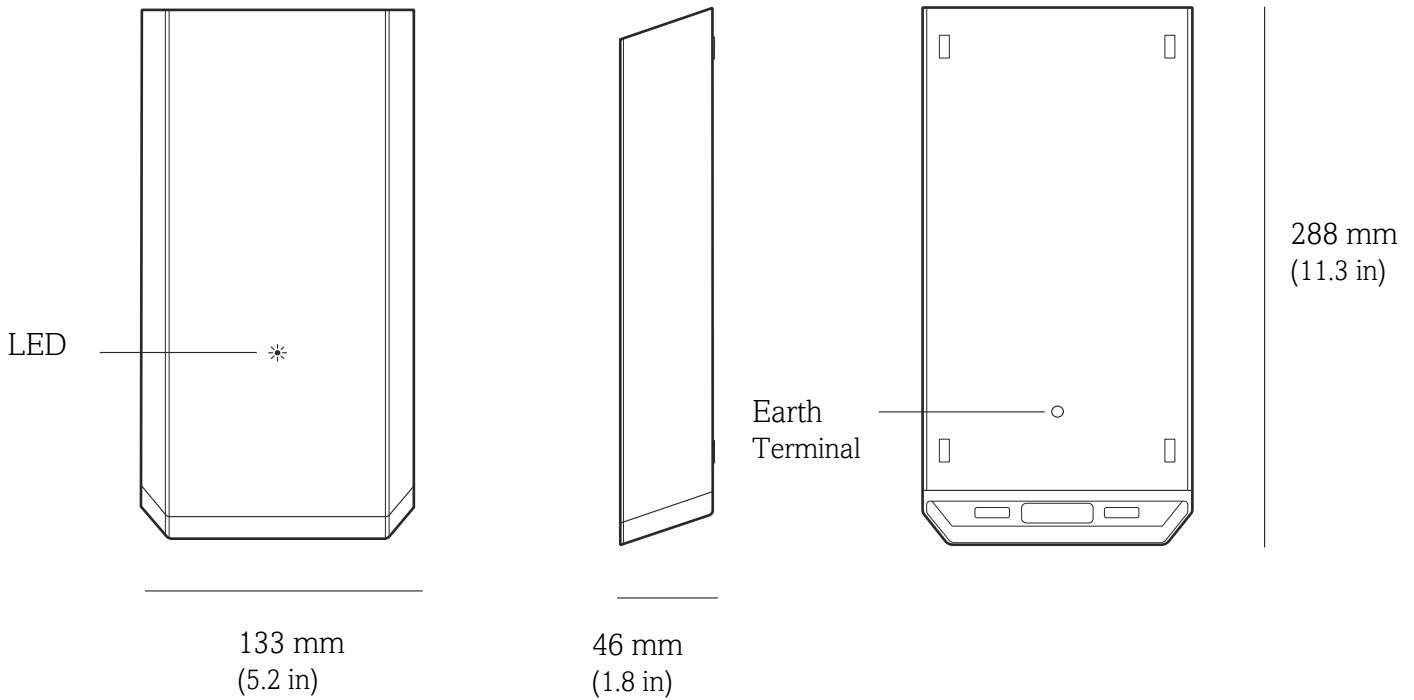

Environmental Rating	IP66
Operating Temperature	-30°C to 50°C (-22 to 122°F)
Weight	1.5kg (3lbs)
Grounding	Dedicated Earth Terminal
Power Specifications	100-240V - 6.3A 50 - 60 Hz
Mounting	Included Mount

## Power Supply Mount

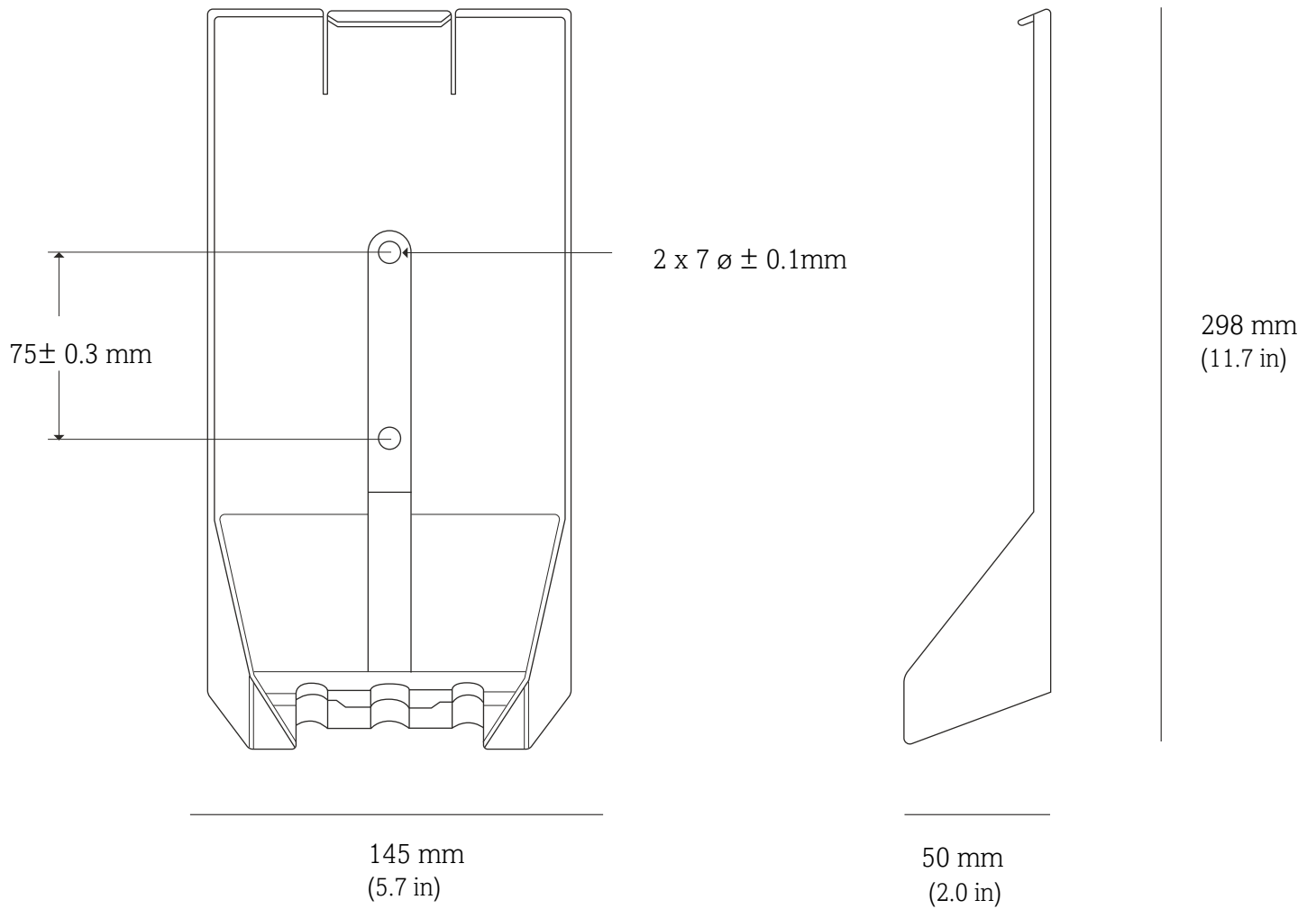

# Enterprise Cable

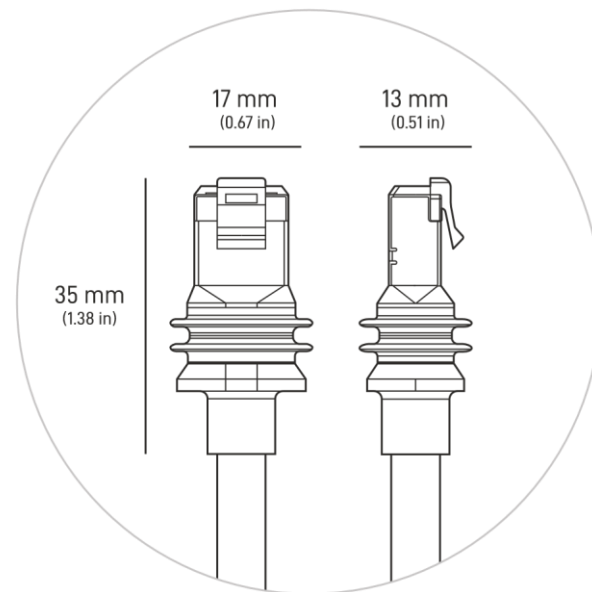
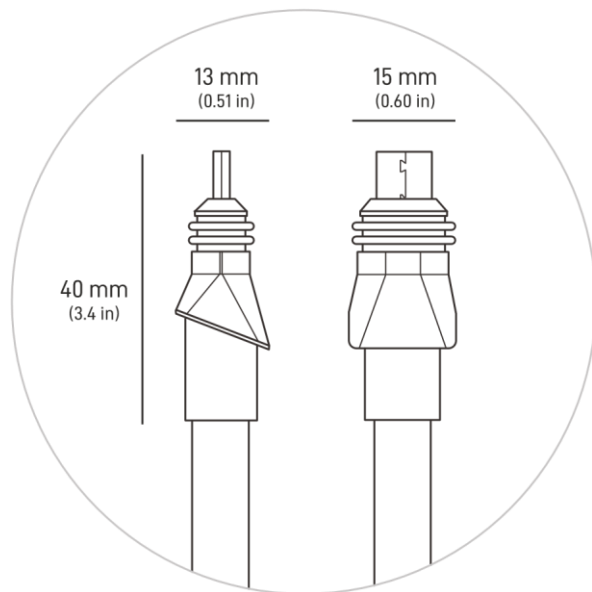
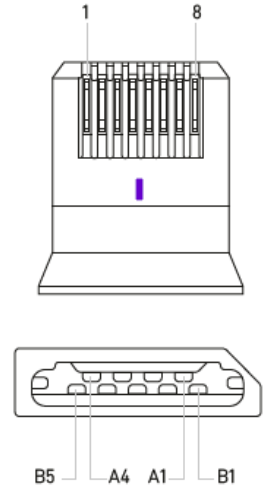
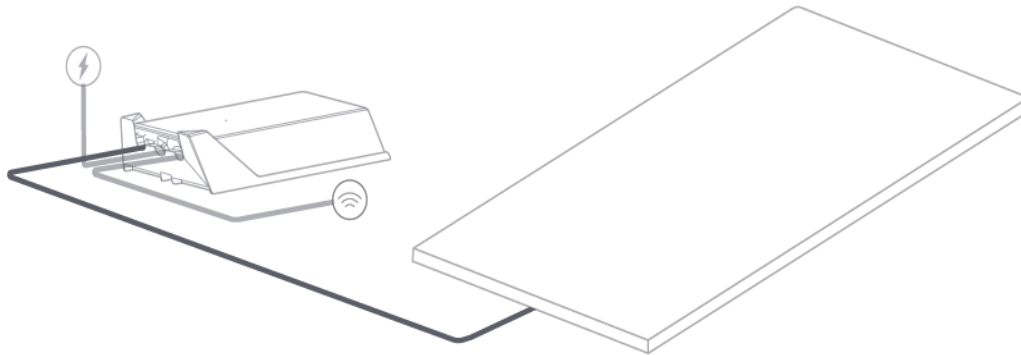

End Dish	Pin	Wire Colour
	1	Blue White
	2	Green
	3	Purple
	4	Orange
	5	Yellow
	6	Brown
	7	Gray
	8	Drain Wire
	SHIELD	

Wire Colour	Pin	End Power Supply
Green	A1	
Yellow	A2	
Blue	A3	
White	A4	
Orange	B1	
Purple	B2	
Brown	B3 B4	
Gray	B5	
Drain Wire		
Drain Wire	SHEILD	

# STARLINK

# Ethernet Cable

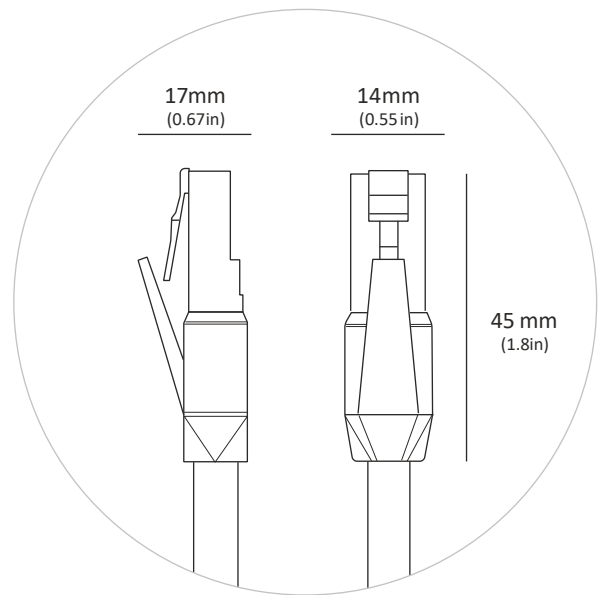
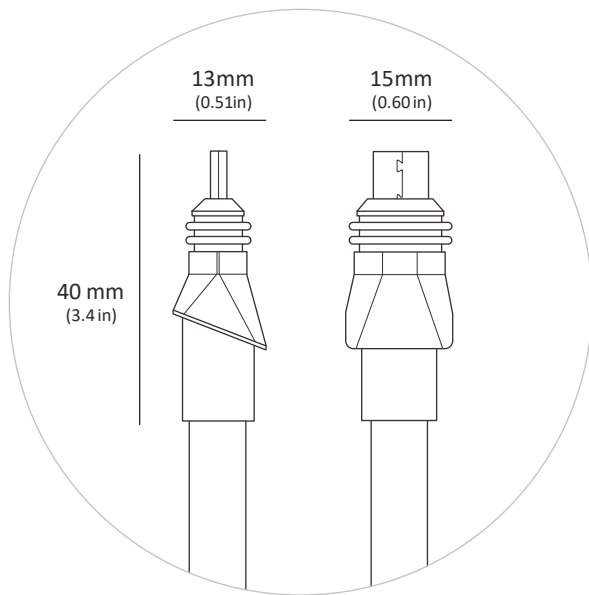
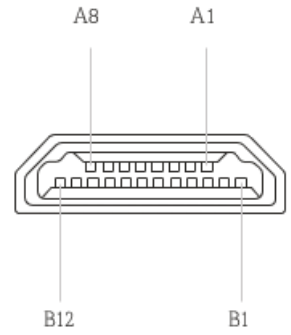
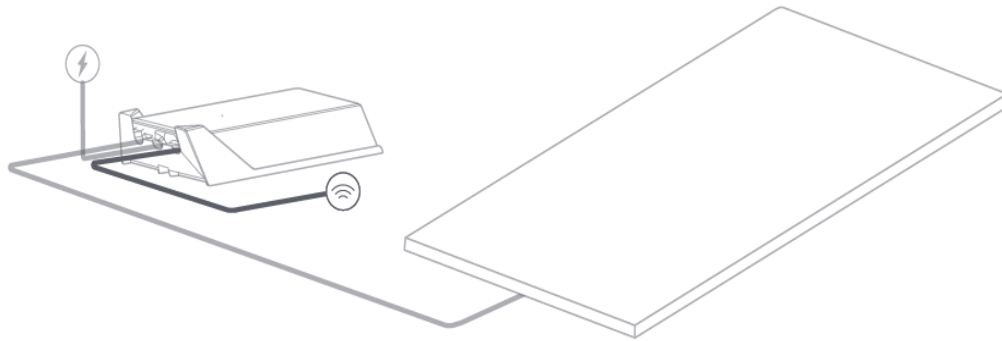

End	Pin	Ethernet Pin	Wire Colour	Pin	End
RJ45	A1, A2	B+	Orange White	A1, A2	Power Supply
	A3, A4	B- A+	Orange	A3, A4	
	A5, A6	A-	Green White	A5, A6	
	A7, A8	--	Green	A7, A8	
	B1, B2	--	N / C	B1, B2	
	B3, B4	D+	N / C	B3, B4	
	B5	D-	Brown White	B5	
	B6	C- C+	Brown	B6	
	B7	--	Blue White	B7	
	B8	--	Blue	B8	
	B9, B10	--	N / C	B9, B10	
	B11, B12	--	N / C	B11,	
	Shield Can	--	Drain Wire	B12	
			Shell		